



ToughBuilt Industries, Inc.
6671 S. Las Vegas Blvd.
Building D, Suite 210
Las Vegas, NV 89119 USA

Made in China



OPERATING / SAFETY INSTRUCTIONS

100' Cross-Line Laser Level

TB-H2-LL-100-L2

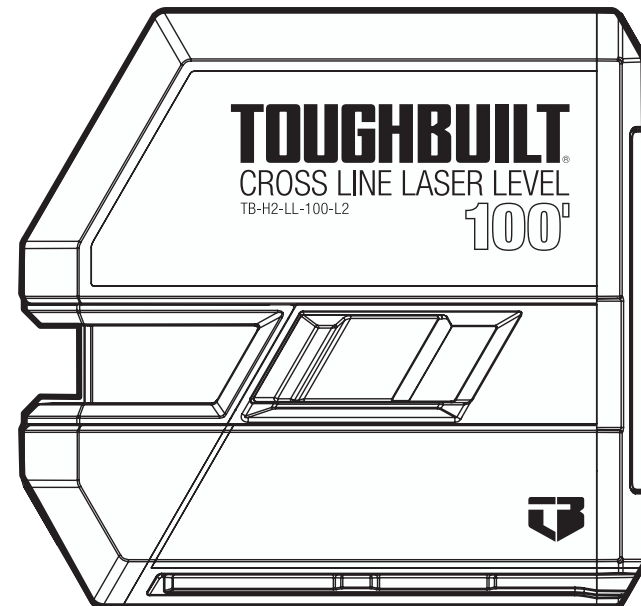

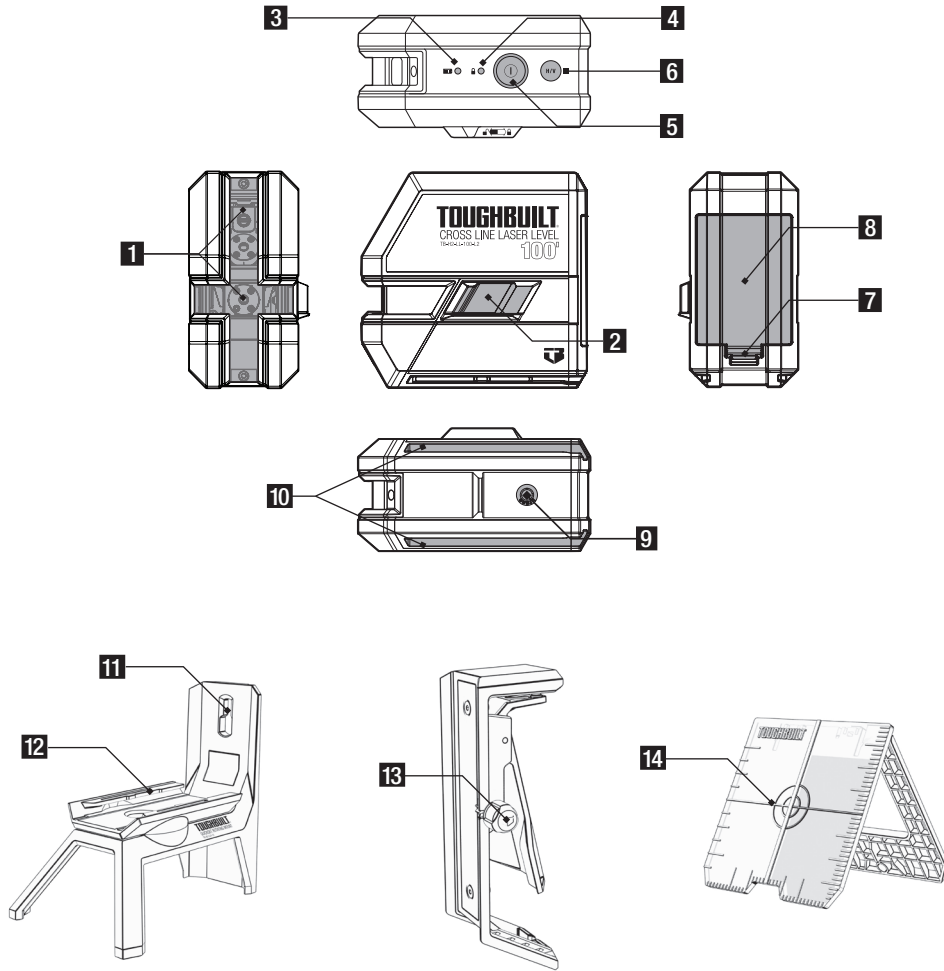

1 Laser Beam Window

2 Pendulum Switch

3 Battery Charge Level Indicator

4 Pendulum Locked Indicator

5 Power ON/OFF Button

6 H/V Laser Beam Selector Button

7 Battery Compartment Latch

8 Battery Compartment Cover

9 Threaded Mount

10 QuickSet® Mount

11 Keyhole Slot

12 QuickSet® Rails

13 Height-Adjustment Knob

14 Laser Target Plate

TABLE OF CONTENTS

1. SAFETY AND PRECAUTIONS	1
2. PRODUCT INFORMATION	
Intended Use	5
What is Included	5
Specifications	6
3. HOW TO OPERATE	
Installing the Batteries	7
Powering ON/OFF	7
Setting the Operating Function	9
QuickSet® Rotating Mount and Ceiling Bracket	9
Using QuickSet® Rotating Mount	10
Using Ceiling Bracket	12
Working with the Laser Target Plate	12
4. ACCURACY CHECK	13
5. TROUBLESHOOTING	20
6. CARE AND MAINTENANCE	
Cleaning	21
Storage	21
7. DISPOSAL	21
8. WARRANTY AND REGISTRATION	
Warranty Information	22
Online Registration	22

Before using this product, review and familiarize yourself with the contents of this manual.

The specifications and general appearance of the instrument are subject to change without notice and without obligation by ToughBuilt® Industries, Inc. and may differ from those appearing in this manual.

1. SAFETY AND PRECAUTIONS

SAVE ALL WARNINGS AND INSTRUCTIONS FOR FUTURE REFERENCE

General Safety Rules

This instrument is a sensitive, precision instrument and should be treated as such.

▲ WARNING! Read and understand all instructions. Failure to follow all instructions below may result in exposure to hazardous radiation, electrical shock, fire, and/or serious injury.

▲ WARNING! THIS DEVICE IS A CLASS 2 LASER PRODUCT IN ACCORDANCE WITH IEC 60825-1:2014 AND EMITS VISIBLE LASER BEAMS.

- **DO NOT** allow persons who are unfamiliar with this device, the device operating manual, and these safety instructions to operate this device.
- **DO NOT** stare directly into a beam or use any optical instruments to view the laser beam. Serious eye injury could result.
- If a laser beam strikes your eyes, immediately close your eyes, and turn away.
- **DO NOT** direct it at others. Serious eye injury could result.
- **DO NOT** set the laser beam at eye level.
- **CAUTION!** Eye exposure to laser beam increases for people who are wearing prescription glasses/lenses.
- **DO NOT** use this laser device for anything other than its intended purpose.
- **DO NOT** disassemble or modify the device. Tampering with this device may result in hazardous laser radiation exposure and will automatically void all warranties.
- **DO NOT** leave the device turned on when unattended. Always turn off the device when it is not in use.
- **DO NOT** operate the laser device around children nor allow children to operate the laser device.
- **ALWAYS** position the laser device securely. Damage to the laser device and/or injury to the user could result if the laser device falls.
- **ALWAYS** use ToughBuilt accessories specifically designed for this product. The use of any other accessories may create a risk of injury.

The following label is on your laser device:

▲ WARNING! DO NOT remove or deface warning labels.



The label may include the following symbols:

Symbol	Meaning	Symbol	Meaning
V	Volts		Read the instruction manual
mW	Milliwatts		Warning / Caution
	Laser Warning		Risk of eye injury. Wear ANSI-approved safety goggles with side shields.
nm	Wavelength in Nanometers		DO NOT Stare Into Beam.
LASER 2	Class 2 Laser Product		Laser Radiation.

Safety Symbols

The definitions below describe the level of severity for each signal word. Please read the manual and pay attention to these symbols.

	This is the safety alert symbol. It is used to alert you to potential personal injury hazards. Obey all safety messages that follow this symbol to avoid possible injury or death.
▲ DANGER	DANGER: Indicates an imminently hazardous situation which, if not avoided, will result in serious injury or death.
▲ WARNING	WARNING: Indicates a potentially hazardous situation which, if not avoided, could result in serious injury or death.
▲ CAUTION	CAUTION: Indicates a potentially hazardous situation which, if not avoided, may result in minor or moderate injury.
IMPORTANT!	Indicates a practice not related to personal injury which, if not avoided, may result in malfunction or property damage.

Battery Safety Instructions

▲ WARNING! Batteries can explode or leak and cause injury or fire if installed backward, disassembled, or exposed to water, fire, or high temperature. To reduce this risk:

- **ALWAYS** follow the instructions and warnings on the battery label and packaging.
- **ALWAYS** keep batteries out of reach of children.
- **DO NOT** charge alkaline batteries.
- **ALWAYS** insert batteries correctly noting the polarity (+ and -) marked on the battery and the equipment.

- **DO NOT** mix old and new batteries. Replace all batteries at the same time, with the same make, brand, and charge level.
- **DO NOT** mix rechargeable and non-rechargeable batteries.
- **DO NOT** mix battery chemistries.
- **DO NOT** short battery terminal.
- **ALWAYS** check battery posts in the battery compartment for corrosion. Clean the posts before use.
- **DO NOT** use batteries with corroded terminals.
- **DO NOT** incinerate or dismantle batteries.
- **DO NOT** dispose of batteries in fire.
- **DO NOT** store or use in locations where the temperature may reach or exceed 105 °F (40,5 °C), store in a cool, dry place.
- **ALWAYS** remove batteries if the device will not be used for an extended period. In storage, batteries may corrode and self-discharge.
- Under abusive conditions, liquid may be ejected from the battery, avoid contact. If contact accidentally occurs, flush with water. If liquid contacts the eyes, additionally seek medical help. Liquid ejected from the battery may cause serious injury.

Work Area Safety

- **AVOID** dangerous environments.
- **ALWAYS** make sure that any bystanders in the vicinity of use are made aware of the dangers of staring directly into the laser beam.
- **AVOID** extended exposure to damp or wet locations.
- **DO NOT** use in the presence of explosive atmospheres (gaseous fumes, dust, or flammable materials).
- **KEEP** the work area clean and well lit. Cluttered or dark areas invite accidents.

Personal Safety

- Stay alert, watch what you are doing, and use common sense when operating the device.
- Secure loose clothing, jewelry, and long hair.
- **DO NOT** use the device while you are tired. A moment of inattention while operating a device may result in serious personal injury or incorrect measurement results.
- **DO NOT** operate devices and machinery when under the influence of alcohol, medication, or drugs.

- **Use safety equipment.** Always wear ANSI-approved safety goggles. Safety equipment such as dust masks, non-skid safety shoes, hard hats, or hearing protection used for appropriate conditions will reduce the risk of personal injuries.

FCC Cautions

This equipment has been tested and found to comply with the limits for a Class B digital device, pursuant to Part 15 of the FCC Rules. These limits are designed to provide reasonable protection against harmful interference in a residential installation. This equipment generates, uses and can radiate radio frequency energy and, if not installed and used in accordance with the instructions, may cause harmful interference to radio communications.

However, there is no guarantee that interference will not occur in a particular installation. If this equipment does cause harmful interference to radio or television reception, which can be determined by turning the equipment off and on, the user is encouraged to try to correct the interference by one or more of the following measures:

- Reorient or relocate the receiving antenna.
- Increase the separation between the equipment and receiver.
- Consult the dealer or an experienced radio/TV technician for help.

2. PRODUCT INFORMATION

Intended Use

This instrument is a self-leveling cross-line laser that projects a horizontal and vertical line for leveling and alignment applications. It can be used for: leveling/aligning suspended objects such as pipes, cable trays, air ducts, and acoustical ceilings; leveling electrical outlets; leveling/aligning doors, windows, and cabinets; transferring heights.

Additionally, when the Pendulum Switch **2** is in the locked position, the instrument can project a tilted line for inclined applications, such as hand rails, staircases, etc.

What is Included

- A** 1 x 100' Cross-Line Laser Level
- B** 1 x QuickSet® Rotating Mount
- C** 1 x Ceiling Bracket
- D** 1 x Laser Target Plate
- E** 1 x Carrying Pouch
- F** 3 x AA Batteries*

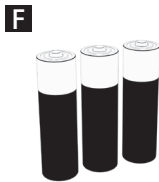
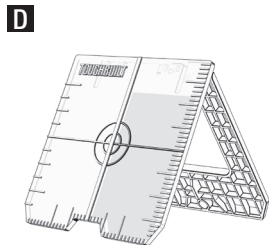
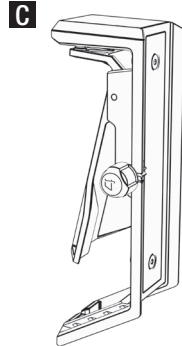
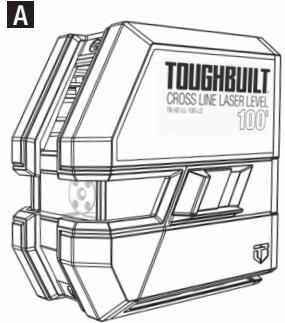

* Batteries that ship with the instrument are not warranted by ToughBuilt®.

Specifications

Laser Beam Function	1 Vertical / 1 Horizontal Cross-Lines
Working Range*	Up to 100' (30,5m)
Laser Beam Color	Green
Laser Type	Emission Wave Length of 510 ~ 530 nm, Class 2, <1 mW
Accuracy*	± 1/8" @ 33' (± 3,18mm @ 10,1m)
Self-Leveling Range	± 4° degrees
Operating Temperature	14 °F ~ 122 °F (-10 °C ~ +50 °C)
Power Source	3 x AA alkaline or rechargeable batteries
Operating Time	5.5 hours (Both laser beams lit)
Mounting Options	a) QuickSet® mount b) 1/4"-20 thread
Instrument Dimensions (L x W x H)	4.33 x 2.28 x 4.13 in (110 x 58 x 105 mm)
Instrument Weight (without batteries)	0.80 lb (0,36 kg)

* Measuring accuracy and working range are dependent on lighting conditions of the work environment.

3. HOW TO OPERATE

▲ CAUTION! When moving the instrument from a warm environment into a cool environment, moisture may accumulate on the Laser Beam Window **1**. Allow the instrument to adapt to the new environment first. **DO NOT** turn on a wet or damp instrument. To wipe the Laser Beam Window **1**, use **ONLY** a lint-free cloth. **DO NOT USE A PAPER TOWEL.**

PLEASE NOTE: Laser beam expands as the distance between the instrument and the target increases. Therefore, always take measurements in the center of the laser line.

Installing the Batteries

Before installing or replacing the batteries, make sure that the Pendulum Switch **2** is in the LOCK position, and the power is turned OFF.

1. Open the Battery Compartment Cover **8** by pushing the latch **7** and lifting it.
2. Insert the batteries observing the polarity. Ensure that the removal band is positioned under the batteries.
3. Close the Battery Compartment Cover **8** until it engages.

Powering ON/OFF:

The instrument can be used in either a *Self-Leveling Mode* (for level applications) or *Pendulum-Locked Mode* (for inclined applications).

Powering ON/OFF in the Self-Leveling Mode:

In this mode, the laser beam self-levels within $\pm 4^\circ$ to project horizontal and vertical laser lines.

1. Before powering ON, place the instrument on a firm and level surface.
2. Slide the Pendulum Switch **2** to the UNLOCK position to activate the laser and wait until it stabilizes.

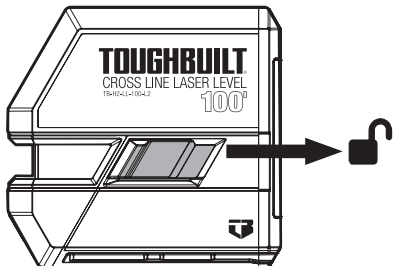

NOTE: If the instrument is tilted beyond its self-leveling limits ($\pm 4^\circ$), the Pendulum Locked Indicator **4** will flash and the laser beam will rapidly flash. Reposition the instrument until the beam stabilizes and the indicator stops flashing.

3. To power OFF, slide the Pendulum Switch **2** to the LOCK position and press the Power ON/OFF Button **5**.

Powering ON/OFF in the Pendulum-Locked Mode:

In this mode, the self-leveling capability is disabled, and the laser level can be tilted to project horizontal and vertical laser lines at an incline.

1. Press the Power ON/OFF button **5** for three seconds to activate the laser.
2. Pendulum Locked Indicator **4** will flash and the laser beam will slowly flash (approx. every 6 seconds).
3. To power OFF, press the Power ON/OFF Button **5**.

Setting the Operating Function

The instrument has 3 operating functions:

- Cross-line (horizontal and vertical laser lines)
- Horizontal line only
- Vertical line only

1. To activate the Cross-Line Function, Power ON the instrument. This is a default function, and it is automatically activated when the instrument is Powered ON.
2. To activate the Horizontal Line Function, press the H/V Laser Beam Selector Button **6** one time.
3. To activate the Vertical Line Function, press the H/V Laser Beam Selector Button **6** second time.
4. To return to the Cross-Line Function, press the H/V Laser Beam Selector Button **6** once again.

All functions can be selected both in the *Self-Levelling Mode* and in the *Pendulum-Locked Mode*.

QuickSet® Rotating Mount and Ceiling Bracket

The QuickSet® Rotating Mount and Ceiling Bracket allow mounting the laser instrument to project the laser beam lines in the desired positions.

They can be attached to various upright surfaces such as steel and wood framing studs, steel door frames, I-beams, angle iron or acoustical ceiling grid.

Only use ToughBuilt® accessories that are designed for this product.

Using QuickSet® Rotating Mount

1. To attach the laser instrument to the QuickSet® Rotating Mount, slide the rear side of the laser instrument into the QuickSet® Rails **12**.

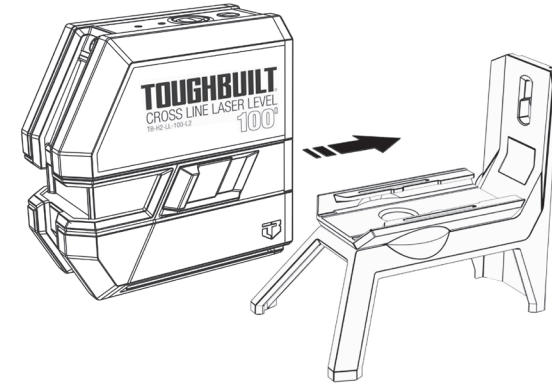

2. Place the QuickSet® Rotating Mount with an instrument on a flat surface.
3. To adjust the position of the projected vertical laser line, rotate the instrument to the left or to the right.

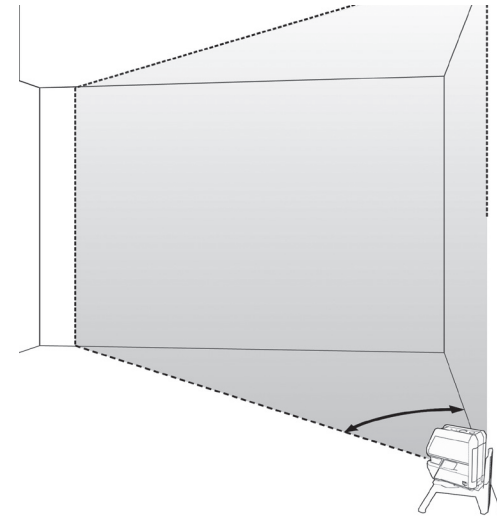

4. To attach the laser instrument to drywall or wood walls, hang the instrument from a nail or No.8 screw using the Keyhole Slot **11**.

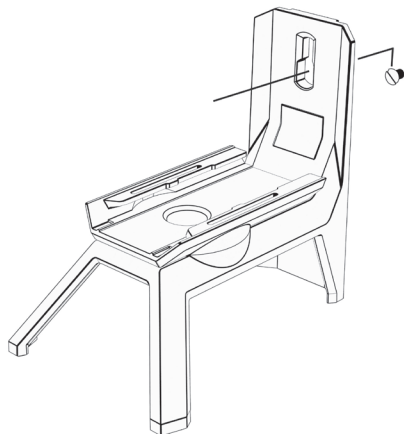

5. To attach the laser instrument to steel surfaces, use the magnets on the rear side of the QuickSet® Rotating Mount.

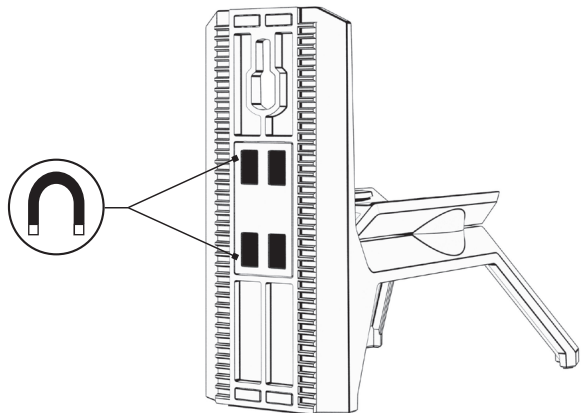

Using Ceiling Bracket

1. To attach the laser instrument onto the angle iron or ceiling grid, first, attach the magnetic rear side of the QuickSet® Rotating Mount to the Ceiling Bracket. Then affix the clamp of the Ceiling bracket to the horizontal section of the steel object.
2. To adjust the height of the horizontal line, turn the Height-Adjustment Knob **13** clockwise to lower the instrument and counterclockwise to raise it.

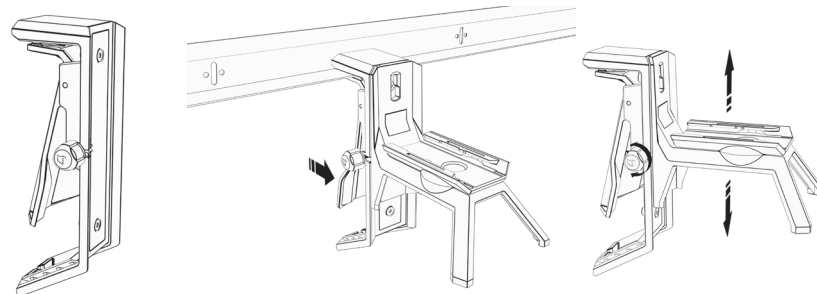

TIP: It is recommended to clean the magnets of the QuickSet® Rotating Mount before attaching it to any steel surface to ensure optimal hold to the mounting surface. Cleaning reduces the interference of dust and debris between the magnetic surfaces.

Working with the Laser Target Plate

The Laser Target Plate **14** improves the visibility of the laser beam under unfavorable light conditions and at long distances within the working range limits. Use the visible cross-line markers on the front side of the target plate as a reference to determine the vertical and horizontal line positions.

Magnets allow attaching the Target Plate **14** to steel surfaces, for hands-free leveling of the suspended objects. Kickstand allows positioning the Target Plate **14** on flat surfaces.

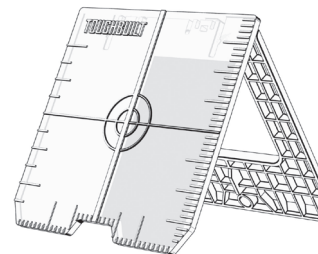

Contact ToughBuilt® Customer Service for additional support.

4. ACCURACY CHECK

This instrument requires no calibration. The regular accuracy checks ensure that the instrument's accuracy has not been impaired by falls or heavy impacts.

It is recommended to check the laser level accuracy each time before beginning workday usage. The accuracy check procedure includes three steps: the horizontal line height check (*step 1*), the horizontal line leveling check (*step 2*), the vertical line leveling check (*step 3*).

If, during one of the tests, the measured deviation exceeds the allowable deviation, repeat the test procedure. Should the readings persist over the allowable deviation, the instrument is out of calibration and must be serviced.

Contact ToughBuilt® Customer Service for additional support.

The following accuracy check procedure suggests the most practical scenarios at the recommended distance.

The surface of the area where the accuracy check procedure is conducted must be sufficiently level, so that the instrument remains within the self-leveling range of $\pm 4^\circ$ from the 0° level position.

Step 1: Checking the Height Accuracy of the Horizontal Line

For this check, a minimum measuring distance of 16' (5m) from the instrument to the opposite wall in a dimly lit room is required.

1. Place the instrument on a firm and level surface or mount the instrument onto a tripod close to *wall A*.
2. Turn on the instrument in the self-leveling mode by sliding the Pendulum Switch **2** to the UNLOCK position.
3. Direct the laser beam against wall A and allow a few seconds for the visible line to stabilize. Mark the center of the horizontal line projected by the instrument on *wall A* (*point a1*).

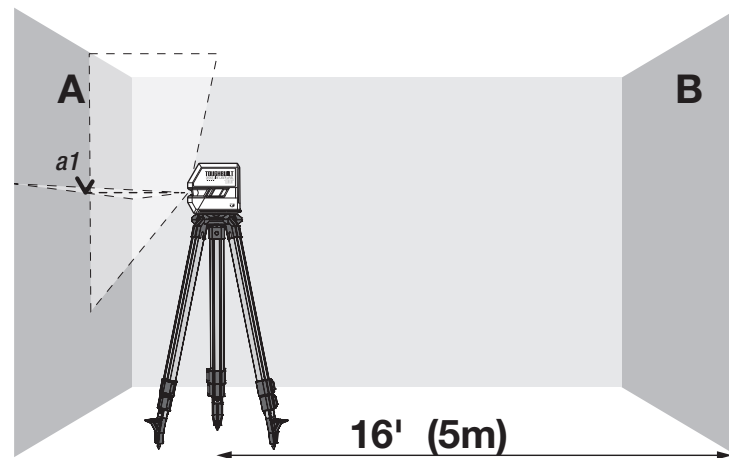

4. Rotate the instrument by 180° , allow it to self-level, and mark the center of the horizontal line on the opposite *wall B* (*point b*).

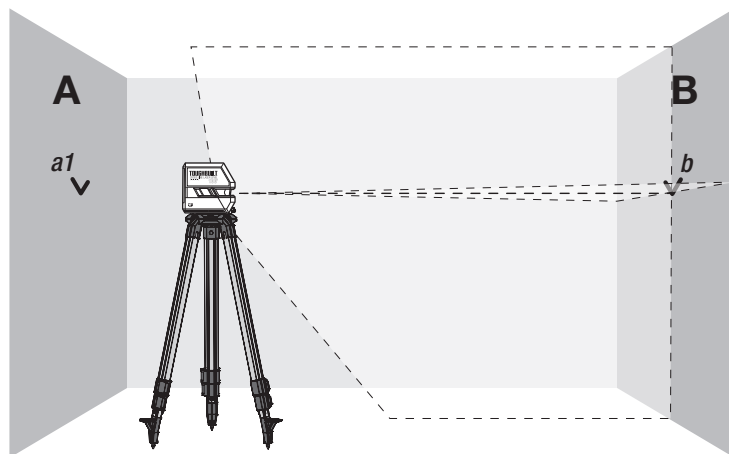

5. Slide the Pendulum Switch **2** to the LOCK position.
6. Without turning the instrument, place it close to *wall B*.
7. Slide the Pendulum Switch **2** to the UNLOCK position and allow the visible line to stabilize.

8. Align the height of the horizontal laser line (using the tripod or by placing objects underneath the instrument as required) with the previously marked *point b* on *wall B*.

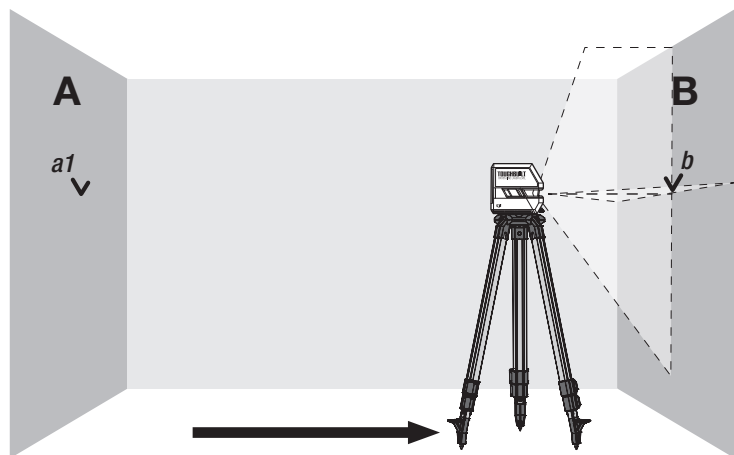

9. Without changing the height, rotate the instrument 180° to direct the laser beam toward *wall A*.

10. Allow the instrument to self-level and mark the center of the horizontal line on *wall A* (*point a2*).

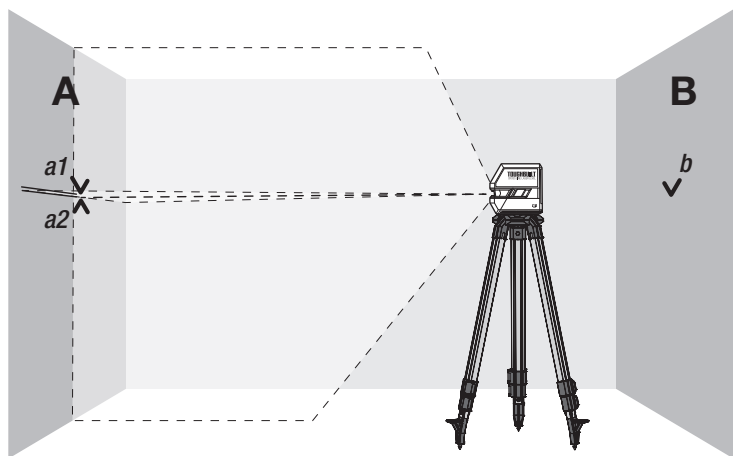

15

11. Measure the vertical distance between *a1* and *a2* that indicates the actual height deviation of the instrument.

If the actual deviation is greater than the Allowable Deviation for the corresponding Distance Between Walls in the table below, the instrument must be serviced.

Distance Between Walls	Allowable Deviation
33' (10m)	± 1/8" (± 3,18mm)
66' (20m)	± 1/4" (± 6,35mm)
100' (30,5m)	± 3/8" (± 9,53mm)

Step 2: Checking the Leveling Accuracy of the Horizontal Line

For this check, a 16' (5m) or 30' (9m) distance to the opposite wall in a dimly lit room is required.

1. Place the instrument on a firm and level surface or mount the instrument onto a tripod at the specified distance from *wall A*.
2. Turn on the instrument in the self-leveling mode by sliding the Pendulum Switch **2** to the UNLOCK position.
3. Direct the laser beam against *wall A* (*Pos.1*) and allow a few seconds for the visible line to stabilize. Mark the center of the horizontal line projected by the instrument on *wall A* (*point a1*).

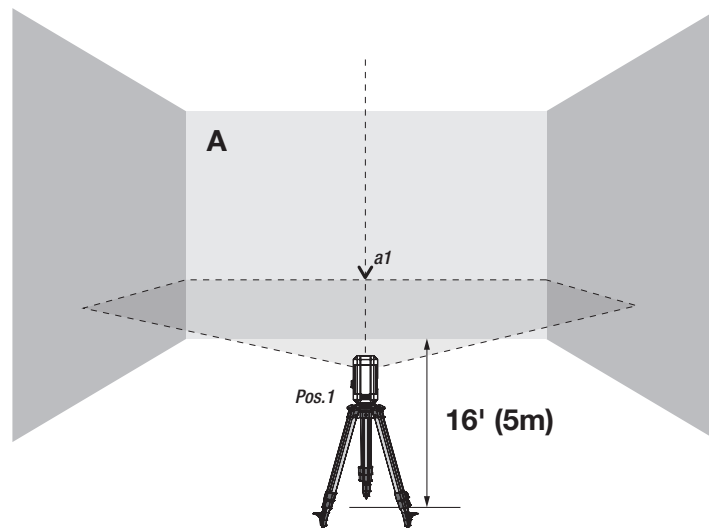

16

- Swivel the instrument 45° to the right to **position 2 (Pos.2)** and mark the horizontal line projected by the instrument on **wall A (point a2)**.
- Swivel the instrument 90° to the left to **position 3 (Pos.3)** and mark the horizontal line projected by the instrument on **wall A (point a3)**.

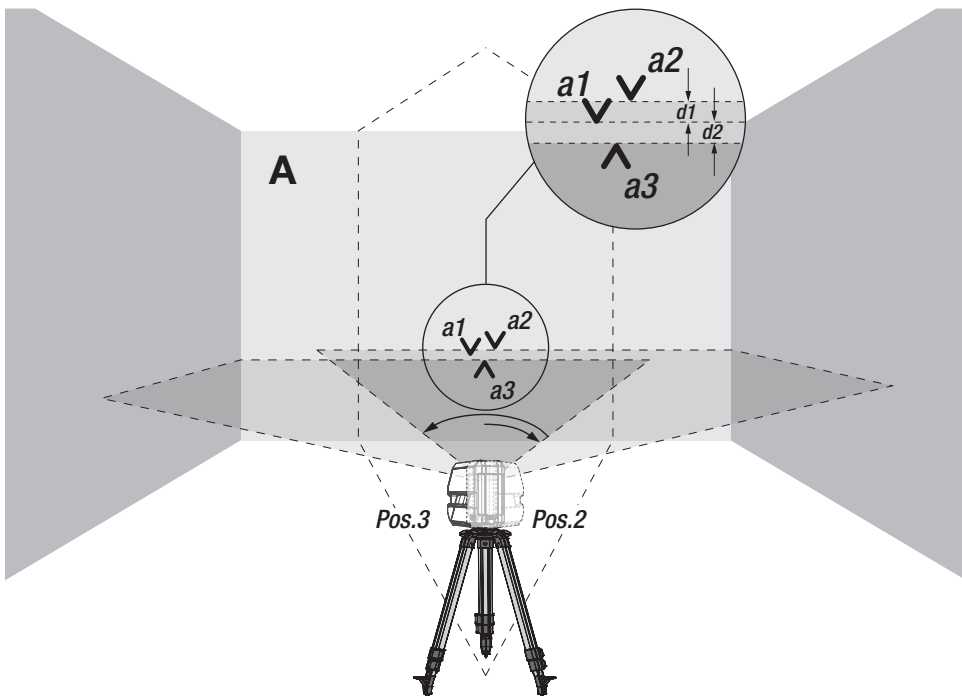

- Measure the vertical distances between marks $d1=a1-a2$, $d2=a1-a3$ that indicate the actual deviation of the instrument.

If any of the actual deviations is greater than the Allowable Deviation for the corresponding Distance to Wall in the following table, the instrument must be serviced.

Distance Between Walls	Allowable Deviation
33' (10m)	± 1/8" (± 3,18mm)
66' (20m)	± 1/4" (± 6,35mm)
100' (30,5m)	± 3/8" (± 9,53mm)

Step 3: Checking the Leveling Accuracy of the Vertical Line

For this check, the most practical recommendation is to consider a door opening with at least 7' (2m) of height clearance and 8' (2,5m) of space to each side of the opening.

- Position the instrument directly on a firm, level floor surface 8' (2,5m) away from the door opening.
- Turn on the instrument in the self-leveling mode by sliding the Pendulum Switch **2** to the UNLOCK position.
- Direct the vertical laser beam to the center of the opening and allow a few seconds for the visible laser line to stabilize.
- Mark the center of the vertical laser line projected by the instrument in three locations: on the floor at the center of the door opening (**point a**), at an 8' (2,5m) distance beyond the other side of the door opening (**point b**), and at the upper edge of the door opening (**point c1**).

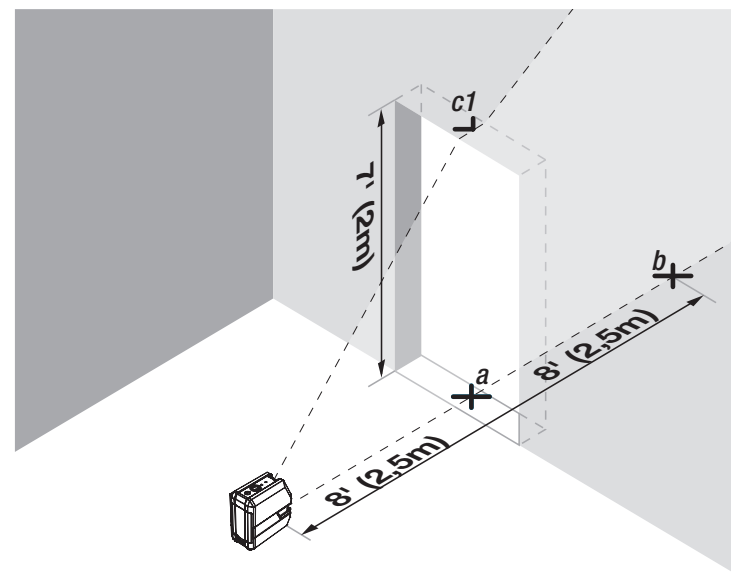

- Position the instrument on the other side of the door opening directly behind *point b*. Allow the instrument to self-level and ensure the vertical laser line aligns with *points a* and *b*.
- Mark the center of the vertical line at the upper edge of the door opening (*point c2*).

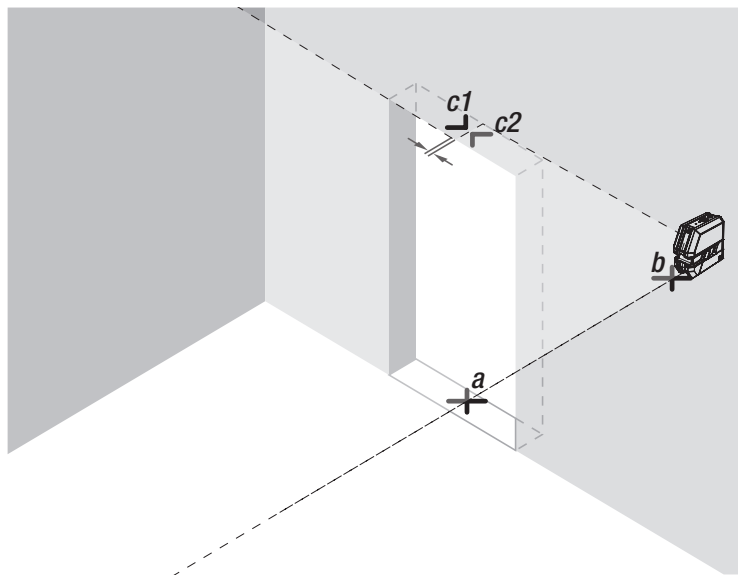

- Measure the distance between *points c1* and *c2* at the upper edge of the door opening that indicates the actual deviation of the instrument from the vertical plane.

If the actual deviation is greater than the allowable deviation for the corresponding Ceiling Height in the table below, the instrument must be serviced.

Ceiling Height	Allowable Deviation
7' (2,1m)	± 1/32" (± 0,79mm)
16' (4,8m)	± 1/16" (± 1,6mm)
33' (10m)	± 3/16" (± 4,78mm)

5. TROUBLESHOOTING

Problem	Possible Cause	Solution
No Laser Beam	Batteries are not inserted	Insert 3 x AA batteries
	Incorrect battery polarity	Check battery polarity
	Low charge or depleted batteries	Replace with new batteries
	Corroded battery terminals	Clean the battery terminals
Fluctuating Beam	Defective Instrument	Contact ToughBuilt® Customer Service
	Instrument tilted beyond its ± 4° self-leveling range	Reposition the instrument
Does Not Self-Level	Depleted batteries	Replace with new batteries
	Temperature is too low or too high	Allow the instrument to cool down or warm up
	Debris on the Laser Beam Window 1	Clean the window with a damp lint-free cloth
Cannot Power-OFF	Instrument is placed on an inclined surface (beyond ± 4°)	Place the instrument on a level surface
Out of Level Laser Beam	Pendulum Switch 2 is in the UNLOCK position.	Slide the Pendulum Switch 2 to the LOCK position, then press the Power ON/OFF button 5 .
	Laser Beam out of leveling calibration	Perform the accuracy check (see the Accuracy check section)

6. CARE AND MAINTENANCE

Cleaning

- Before and after each use, thoroughly inspect the instrument for any damage. If the instrument is soiled, wipe with a damp cloth.
- Blow the debris from the Laser Beam Window **1**.
- If necessary, wipe the Laser Beam Window **1** with a damp lint-free cloth.
- **DO NOT** use aggressive cleaning agents or solvents.
- **DO NOT USE PAPER TOWEL.**
- **DO NOT** touch the Laser Beam Window **1** with fingers.

Storage

- **IMPORTANT!** To prevent damage to the laser mechanism, Pendulum Switch **2** must be in the LOCK position prior to relocation or storage.
- Before storage, make sure the instrument is turned OFF.
- **ALWAYS** store the instrument in its original container (if one is available).
- **DO NOT** leave the instrument in direct sunlight or expose it to high or cold temperatures. (see the recommended Operating temperatures).
- **DO NOT** store a damp or wet unit.
- For extended storage, remove the batteries and store the instrument in a dry, cool place.

7. DISPOSAL



This product must not be disposed of with household waste. Please sort it out for separate recycling.



Separate collection of used products and packaging allows materials to be recycled and used again.

Reuse of recycled materials helps prevent environmental pollution and reduces the demand for raw materials.

Some local governments may require local or municipal waste disposal centers or retailers of new products to provide households with electronic product recycling services.

8. WARRANTY AND REGISTRATION

3-YEAR LIMITED WARRANTY.

(Proof of purchase is required to register the product).

Alkaline batteries that are shipped with the instrument are not warranted by ToughBuilt®. For warranty details, visit www.toughbuilt.com

Online Registration

1. Visit <https://toughbuilt.com/register-your-product> or scan the QR code below to begin the product registration.



2. Fill in the form and upload the proof of purchase.

For product registration support, please call our Customer Service Line:

US: 1 (800) 288-4695

Mexico: +52 55 9225 6212

Canada: +1 844 5751923

Have product and purchase information available when contacting ToughBuilt® Industries for product support.

Specifications are subject to change without notice.

